



**TECHNICAL SPECIFICATIONS**

- Tested according the NCHRP-350 TL II (2-50 | 2-51) 2000P tests were done with a 2000 kg / 4409 lbs US pick-up truck
- TLTMA 70K crash cushion, completely aluminum excluding the galvanised backplate
- Operated by buttons (max 15M) from inside the towing vehicle
- 12V or 24V DC driving lights & side marker lights mounted on cushion impact plate
- Including test certifications and CE mark
- Reflective foil on the cushion hood available on request
- Optional Hydraulic Energy Pack 12V or 24V on request
- Galvanized steel structure, optional painted in your RAL color
- The crash cushion and Tubes can optional be painted in your RAL color(s)

**ABOUT THE TLTMA-US 70K**

With this unique TLTMA 70K (Light Truck Mounted Attenuator) is it possible to add a safety device to your workzone. This TLTMA is for vehicles up to 3.5 tons that are daily used during inner city road works. The unique and light design of the TLTMA makes it possible to use it daily on all sort of roads, up to 70 km/h!

**TLTMA-US 70K ADVANTAGES**

- No moisture problems because of the ALU cushion and galvanized structure
- Great design with aluminum pre-bended tubes on top and bottom of the cushion
- Vibration tested
- Easy replaceable hood (Bolted connection)
- Many color variations possible
- Easy to use
- European Quality
- Spare parts always delivered from stock!
- Will be delivered including documentation and certifications.
- Instruction manual A4 format in English and CE approved

Table of contents and dimensions

Transport height	2676 mm / 8,8 ft
Installation length	4036 mm / 13,2 ft
Width	2033 mm / 6,7 ft
Hood to road	252 mm / 0,8 ft
Weight complete installation	Approx. 907 kg / 2000 lbs

Note: all these dimensions are approximately, no rights can be derived.

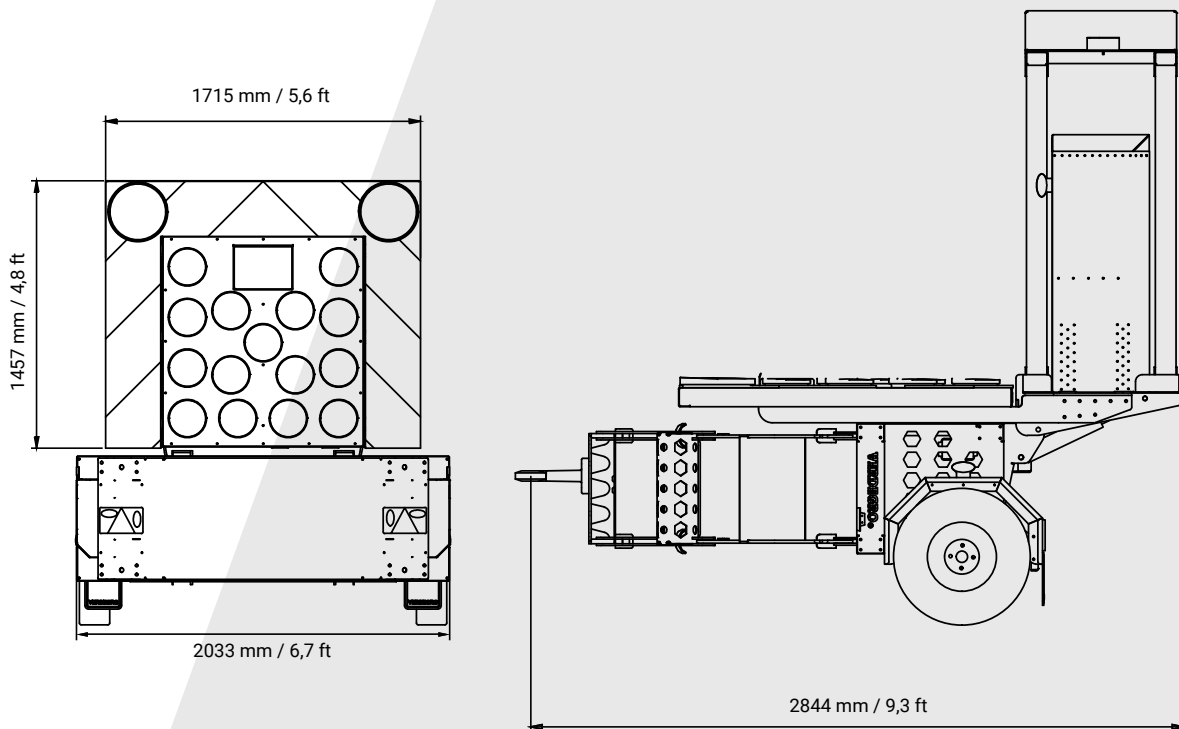

## OPTIONAL

- Hydraulic energy pack system 12Vdc
- Special manual rotating mounting frame for sweepers with bracket to install LP15 mini arrow board
- Welding plates for mounting to a local fabricated subframe mounted between the chassis and cargo body
- Full color VMS 80x80 20mm LED display with reflective foil frame + flashers + 3G/Wifi modem
- Verdegro LP15 mini board (TMA version) 12Vdc with combined wired TMA cabin controller as shown and described
- Dr. Airbrake impact strip installed on TLTMA 70K (not complete system)