



TECHNICAL SPECIFICATIONS

- Tested according the NCHRP-350 TL III (3-50 | 3-51 | 3-52 | 3-53). 2000P tests were done with a 2000 kg / 4409 lbs US pick-up truck
- Tested according the UK optional 110K test
- Standard 100K crash cushion, completely aluminum excluding the galvanised backplate
- Two compartments for some back-up or buffer batteries
- Operation from truck with joystick and a 10 pole connector
- The entire machine can also be operated from the optional control unit on the machine
- At the TMA a plug (175A) is mounted, to power the entire machine from the vehicle
- Whole machine is 12 or 24 Volt performed
- Rear (driving) lights on support structure and crash cushion
- Including test certifications and CE-mark

TMA-US 100K ADVANTAGES

- No moisture problems because of the aluminium cushion and galvanized structure
- Great design with aluminum pre-bended tubes on top and bottom of the cushion
- Vibration tested
- Easy replaceable hood (Bolted connection)
- Optional flash-light / light bar between hood and cushion
- Many color variations possible
- Easy to use
- European quality
- Spare parts always delivered from stock!

Table of contents and dimensions

Transport height	3979 mm / 13 ft
Installation length	4075 mm / 13,4 ft
Width	2300 mm / 7,6 ft
Hood to road	280 mm / 11 inch
Weight complete installation	Approx. 1200 kg / 2650 lbs

Note: all these dimensions are approximately, no rights can be derived.

THIS IS WHY YOU WANT THE TMA-US

- LED taillights integrated in structure + cushion
- Energy absorption replaceable aluminium tubes
- Hydraulic rotating system
- Double safety blocking device
- Bolt connection structure for arrow boards / warning structures
- Steel hot galvanized mounting system
- Energy absorption aluminium moisture proof cartridge
- Forklift tubes for easy handling
- Personalized with two tone paint job
- First impact aluminium replaceable hood
- Reflective foil according your specs
- Available in any RAL color

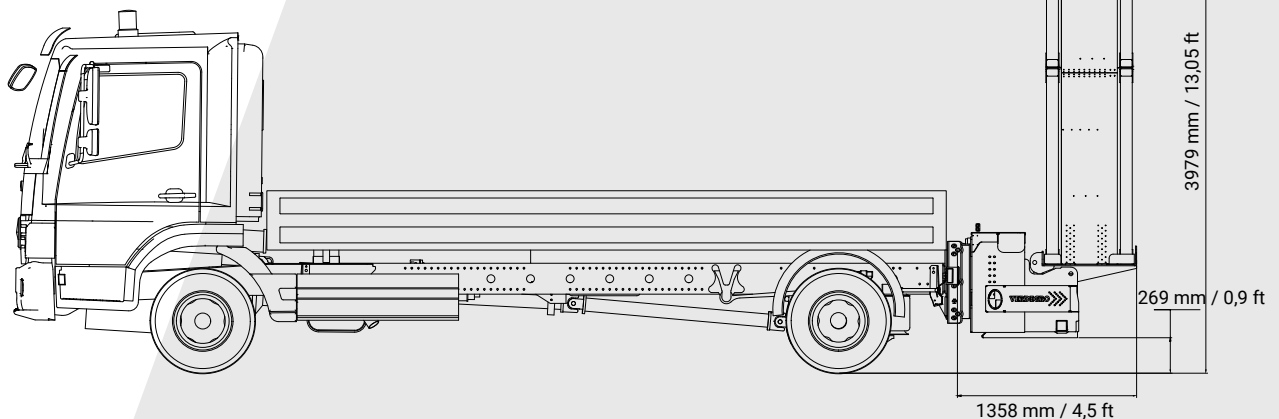

OPTIONAL

Options TMA-US 100K:

- Reflective chevrons on back of TMA cushion
- Contour foil
- Flashers next to license plate

Options arrow board:

- 200mm LED Arrow Board with hydraulic synchronized Blue Arrow Left/Right.
- Reflective Foil on Arrow Board top frame
- Left Arrow, Right Arrow and Cross function on top + hydraulic undersign with blue arrow
- 2 LED 300mm alternating lights on the corners of framework
- Wired Verdegro controller in cabin with combined control TMA-US