



TECHNICAL SPECIFICATIONS

- Tested according the NCHRP-350 TL III (3-50 | 3-51 | 3-52) 2000P tests were done with a 2000 kg / 4409 lbs US pick-up truck
- TTMA 100K crash cushion, completely Aluminum excluding the galvanised backplate
- DIN-Towing eye 40 or 50 (40 standard, 50 on request)
- Tow-eye height of truck needs to be 1000mm (+/- 5%)
- 24V DC driving lights & side marker lamps
- Energy absorbing special design towbar
- Including test certifications and CE-mark
- Jockey wheel with self-acting turnover and locking
- Reflective foil on the cushion hood available on request
- Rubber suspension axle
- Low tire 10inch wheels
- Weight 1600lbs (without optional arrow board)

TTMA-US 100K ADVANTAGES

- No moisture problems because of the aluminium cushion and galvanized structure
- Great design with aluminum pre-bended tubes on top and bottom of the cushion
- Vibration tested
- Easy replaceable hood (Bolted connection)
- Optional flash-light / light bar between hood and cushion
- Many color variations possible
- Easy to use
- European quality
- Spare parts always delivered from stock

Table of contents and dimensions

| | |
|------------------------------|----------------------------|
| Transport height | 1123 mm / 3,6 ft |
| Installation length | 5814 mm / 19,1 ft |
| Width | 2349 mm / 7,7 ft |
| Hood to road | 280 mm / 11 inch |
| Weight complete installation | Approx. 1100 kg / 2400 lbs |

Note: all these dimensions are approximately, no rights can be derived.

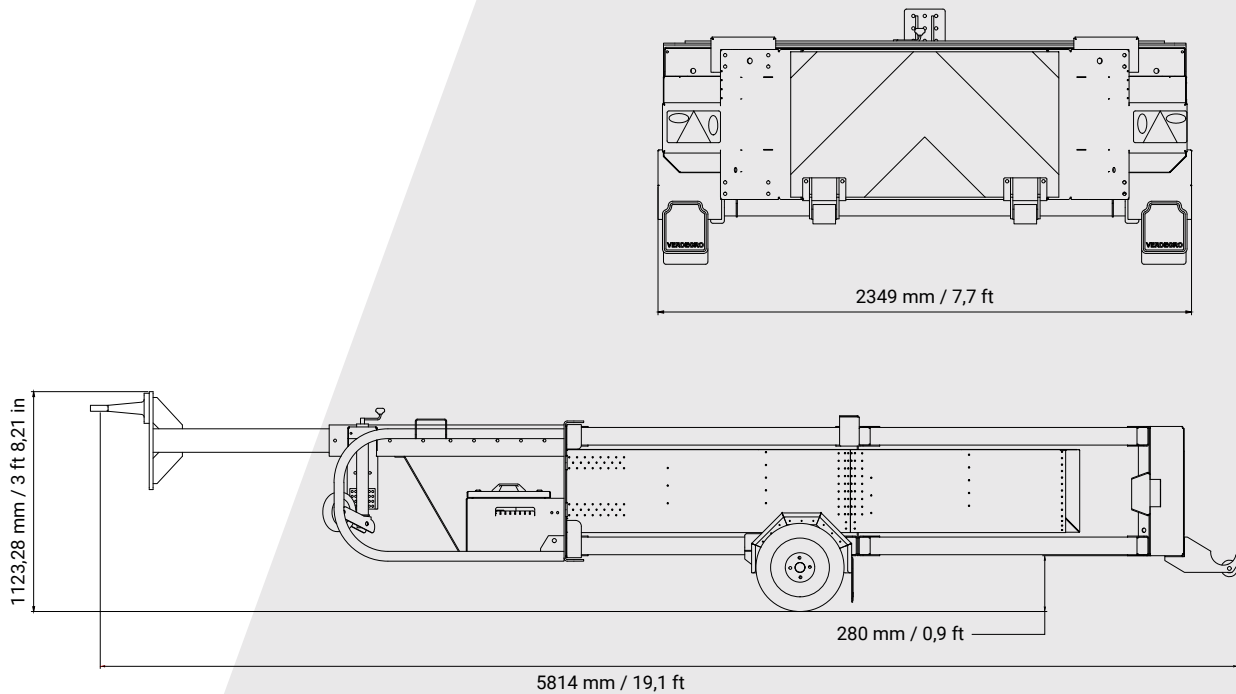

OPTIONAL

- Approved height adjustable towbar with brake system for 1350 kg / 2976 lbs axle (required with optional arrow board if license plate is required above 750 kg / 1653 lbs trailer)
- Hydraulic foldable arrow board on TTME with hydraulic undersign + reflective foil frames according to country specs
- Wireless remote control unit
- Export document/individual trailer homologation by TÜV (if required: for EU license plate documentation)
- Galvanized steel structure, optional painted in your RAL color
- The crash cushion and Tubes can optional be painted in your RAL color(s)
- Export license, individual trailer homologation can be provided